



Project: _____	AIA# _____
Item #: _____ Qty: _____	SIS# _____
Model #: _____	

All-In-One Stations

See reverse side for model number key



ALL-72
(Juice Bottles, Waste Receptacle,
and Blender Not Included)



Standard Features

- All stainless steel construction
- Combines many different underbar components into one pre-assembled unit.
- Combo Ice Bin, Single Wet Waste Sink with faucet and Blender Shelf, Condiment Dispenser, Double Speed Rail, Dry Waste Chute, and Towel Ring standard on all models (see spec pages 3.04, 3.21, 3.32, and 3.26)
- Recessed Drainboards and Liquor Displays are included with some models (see spec pages 3.10 and 3.23)
- A stainless steel side splash is included between the wet waste sink and ice bin
- Ten circuit cold plates available in Combo Ice Bin

★ All faucets are NSF/ANSI 61, Annex G low lead compliant

Specifications

Drains

- Standard model: 1-1/2" tailpiece
- Ten circuit cold plate model: 3/4" MPT
- Drainboard and Wet Waste Sink: 1-1/2" I.P.S.
Threaded drain will fit Dearborn part #8033 slipnut and part #W-573P washer.

Tube Access Holes

- 7/8" by 2-7/8" (capacity per hole is 12 lines of 1/4" I.D. x 3/8" O.D. nylon braided tubing)
- Located one at top on each end of ice bin backsplash

Faucet

- 4" centers, accepts 3/8" sink leads, hot and cold water connections required

Sink Bowl Dimensions

- 11-1/2" long by 9-1/4" wide by 6" deep

Sink Strainer

- Perforated plastic

Legs

- 1-5/8" diameter 16 gauge stainless steel
- Stainless steel bullet feet

Materials

- 20 gauge stainless steel parts include: all components unless otherwise noted
- 18 gauge stainless steel parts include: leg pads
- 14 gauge stainless steel parts include: blender shelf ends, speed rail ends, and liquor display ends

Glastender, Inc. • 5400 North Michigan Road • Saginaw, MI • 48604-9780 989.752.4275 • 800.748.0423 • Fax 989.752.4444 www.glastender.com	Approval/Notes:
Specifications subject to change without notice. For current specifications please visit our website.	

All-In-One Stations

Dimensional Information

Letter	Descriptions
W	Recessed Drainboard Section
X	Combo Ice Bin Section
Z	Liquor Display Section

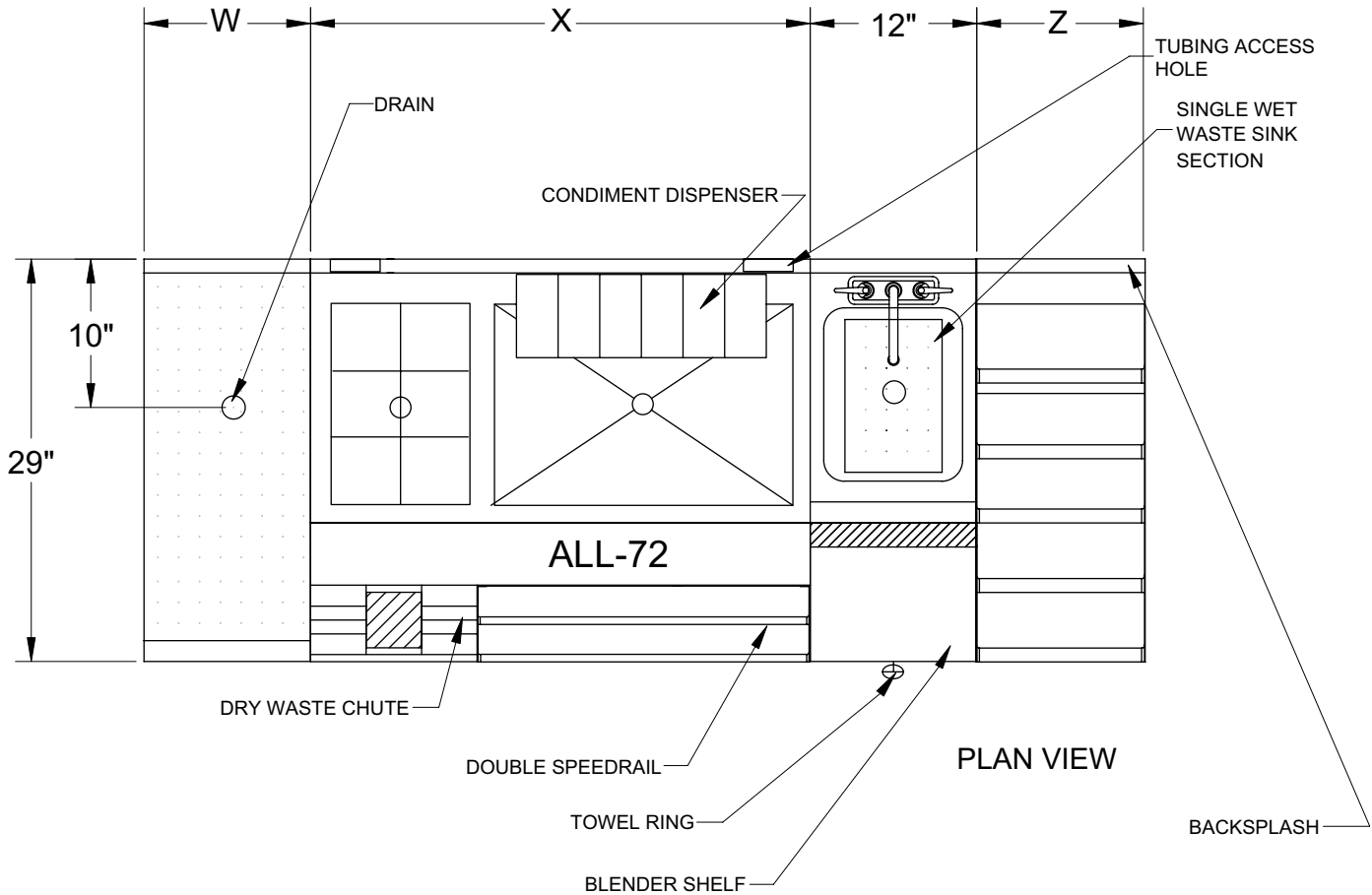

Model Number	W	X	Z
ALL-60A	N/A	36"	12"
ALL-60B	12"	36"	N/A
ALL-66A	N/A	42"	12"
ALL-66B	12"	42"	N/A
ALL-66C	18"	36"	N/A
ALL-66D	N/A	36"	18"
ALL-72	12"	36"	12"
ALL-72A	N/A	42"	18"
ALL-72B	18"	42"	N/A

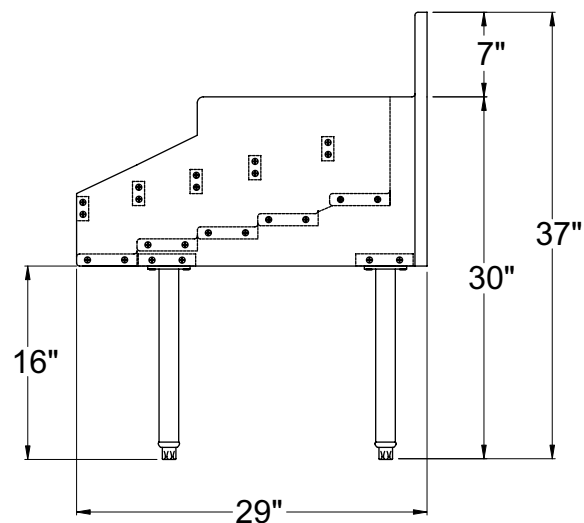

SIDE ELEVATION



5400 North Michigan Road • Saginaw, MI • 48604-9780
 989.752.4275 • 800.748.0423 • Fax 989.752.4444
 www.glastender.com

Printed in USA