



BB24-N1-LLR(R)



COMPONENT



*BB24 units with R404a expansion valves are not UL listed.

NSF standard 7 listed for open food storage

Project: _____	AIA# _____
Item #: _____ Qty: _____	SIS# _____
Model #: _____	

24" Back Bar Cooler One Door Remote

BB24-N - R()

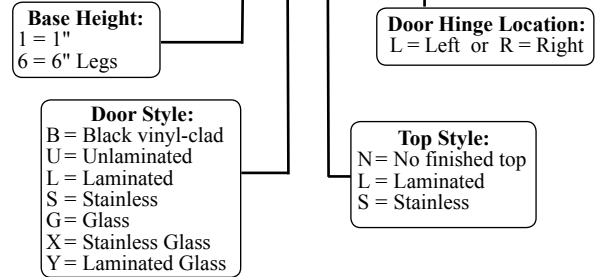

Standard Features

- Remote unit
- All stainless steel interior construction with radius interior corners
- CFC free foamed-in-place insulation
- Galvanized steel sub-top
- Black vinyl-clad steel exterior front and sides
- Stainless steel evaporator housing with separate removable evaporator drain pan
- Stainless steel die cast handle
- Leg sockets recessed into base
- 1/2" thick ABS plastic threshold scuff plate
- 180° swinging doors

Specifications

Electrical

- 120V, 1 phase, 60 Hz
- Dedicated 15 amp circuit is required
- 14 gauge wire connection is made inside the cooler next to evaporator housing

Refrigeration

- R134a or R404a* expansion valve & temperature control included. Specify type required when ordering.
- Recommended condensing unit is 1/4 HP which has an approximate rating of 1,530 BTU/H at +20°F evaporator temperature
- All refrigeration hookups are made at the installation site

Plumbing

- A ten foot length of 1/2" ID by 5/8" OD plastic tubing is provided to drain condensate. The tubing should exit through one of the 3/4" side knock-out holes (installer's choice). The maximum drainage is one ounce per hour - consult local codes for compliance - a floor drain may be required

Shelving

- Two adjustable coated shelves and one bottom coated rack per door included

Capacity

- 5 cases of long neck bottle beer

Legs

- 1-5/8" diameter
- Stainless steel bullet feet

Materials

- 22 gauge stainless steel parts include: interior floor, walls, ceiling, front of cabinet, and evaporator housing
- 22 gauge black vinyl-clad parts include: sides and standard doors
- 22 gauge galvanized steel parts include: exterior sub-top and back
- 16 gauge stainless steel parts include: legs
- 16 gauge galvanized steel parts include: base
- 16 gauge zinc plated CR steel parts include: leg sockets
- 12 gauge stainless steel parts include: hinges, hinge brackets, and lock brackets

Glastender, Inc. • 5400 North Michigan Road • Saginaw, MI • 48604-9780 989.752.4275 • 800.748.0423 • Fax 989.752.4444 www.glastender.com	Approval/Notes:
Specifications subject to change without notice. For current specifications please visit our website.	

One Door Remote Back Bar Cooler

Dimensional Information

PLAN VIEW

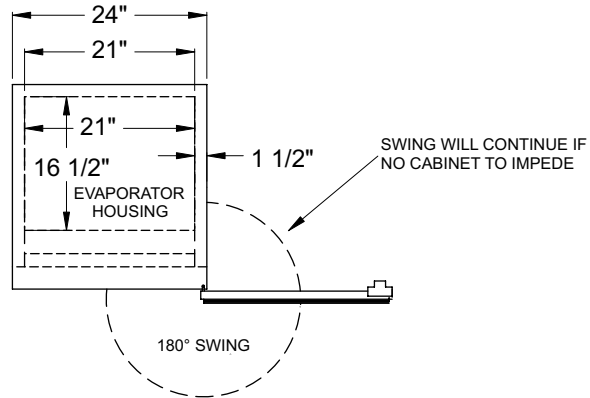

FRONT VIEW

NOTE:
ELECTRICAL AND REFRIGERATION
CONNECTIONS ARE MADE INSIDE
THE COOLER BEHIND THE
EVAPORATOR HOUSING.

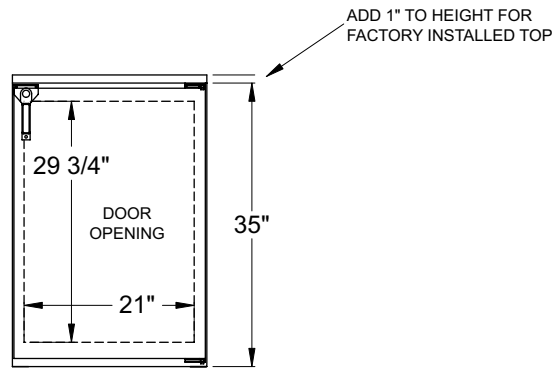

SIDE VIEWS

