



BB60-L1-XSH(LR)



NSF standard 7 listed for open food storage

Project: _____	AIA# _____
Item #: _____ Qty: _____	SIS# _____
Model #: _____	

**Back Bar Coolers**  
**One, Two, Three and Four Door**  
**Self-Contained**

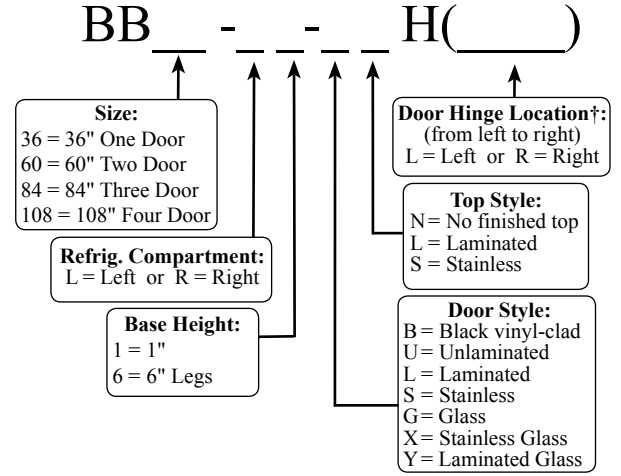

† Specify hinge location for each door

**Standard Features**

- Solid door models meet 2008 energy efficiency standards
- Self-contained
- All stainless steel interior construction with radius interior corners for easy cleaning
- CFC free foamed-in-place insulation
- Galvanized steel sub-top
- Black vinyl-clad steel exterior front and sides
- Automatic defrost timer
- Stainless steel die cast handle
- Automatic condensate evaporator
- Leg sockets recessed into base
- 1/2" thick ABS plastic threshold scuff plate
- 180° swinging doors
- Six foot grounded cord and plug (exits at rear)
- Compressor compartment available on left or right side of unit

**Specifications**

- Electrical**
- 120V, 1 phase, 60 Hz
  - Dedicated 15 amp circuit is required
  - Includes a 6 foot grounded cord and plug which exits the back of refrigeration compartment
- Refrigeration**
- R134a
- Operating Range**
- 34° F to 40° F
- Plumbing**
- Automatic condensate evaporator. No drain connection required
- Shelving**
- Two adjustable coated shelves and one bottom coated rack per door included

- Legs**
- 1-5/8" diameter
  - Stainless steel bullet feet
- Materials**
- 22 gauge stainless steel parts include: interior floor, walls, ceiling, front of cabinet, and evaporator housing
  - 22 gauge black vinyl-clad parts include: sides, standard doors, and compressor compartment housing
  - 22 gauge galvanized steel parts include: exterior sub-top and back
  - 16 gauge stainless steel parts include: legs
  - 16 gauge galvanized steel parts include: base and compressor compartment base plate
  - 16 gauge zinc plated CR steel parts include: leg sockets
  - 12 gauge stainless steel parts include: hinges, hinge brackets, and lock brackets

<p><b>Glastender, Inc.</b> • 5400 N Michigan Rd • Saginaw, MI • 48604-9780          989.752.4275 • 800.748.0423 • Fax 989.752.4444  <a href="http://www.glastender.com">www.glastender.com</a></p>	<p>Approval/Notes:</p>
--	------------------------

Specifications subject to change without notice. For current specifications please visit our website.

# Self-Contained Back Bar Coolers

## Dimensional Information

### BB36

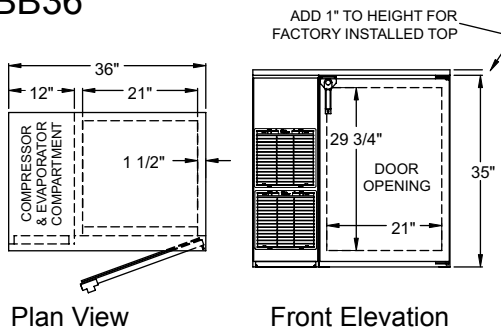

### BB60

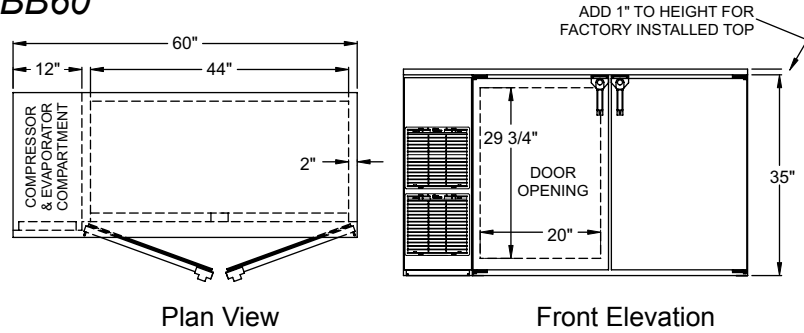

### BB84

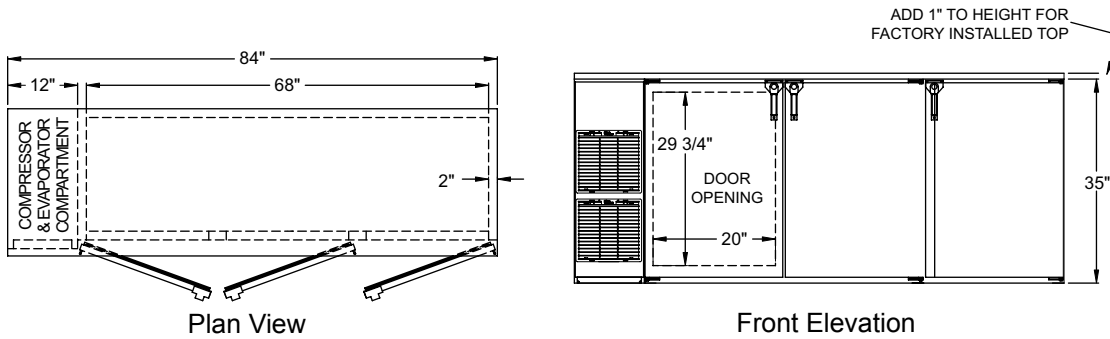

### BB108

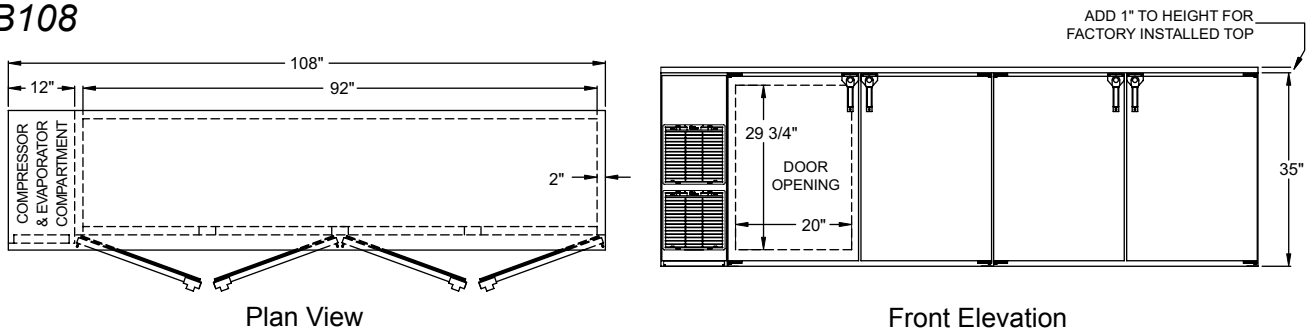

## Side View All Models

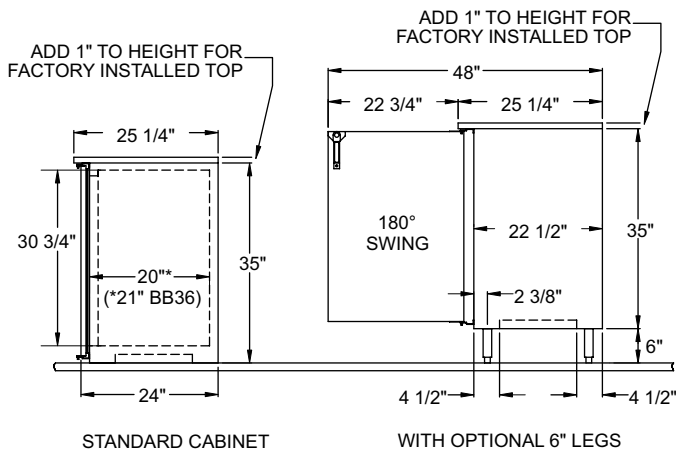

Note: Available with compressor left or right. Compressor left model shown. Use Model Number Key to specify location when ordering.

Model	Capacity: 12 oz. bottle / 1/2 barrels/ 750ml wine bottles	Refrigeration	Voltage	Amps
BB36	7 cases / 1 half barrel/ 78 750ml wine bottles	1/6 H.P. / R134a	120v / 60 Hz / 1 phase	8.2 full load
BB60	15.2 cases / 2 half barrel/ 162 750ml wine bottles	1/4 H.P. / R134a	120v / 60 Hz / 1 phase	6.5 full load
BB84	23.7 cases / 4 half barrels/ 246 750ml wine bottles	1/4 H.P. / R134a	120v / 60 Hz / 1 phase	6.5 full load
BB108	32.2 cases / 5 half barrels/ 330 750ml wine bottles	1/4 H.P. / R134a	120v / 60 Hz / 1 phase	6.5 full load



5400 N Michigan Rd • Saginaw, MI • 48604-9780  
989.752.4275 • 800.748.0423 • Fax 989.752.4444  
www.glastender.com

Printed in USA