



ND60-R1-SS(RRR)



NSF standard 7 listed for open food storage

Project: _____	AIA# _____
Item #: _____ Qty: _____	SIS# _____
Model #: _____	

Narrow Door Coolers Two, Three and Four Door Remote*

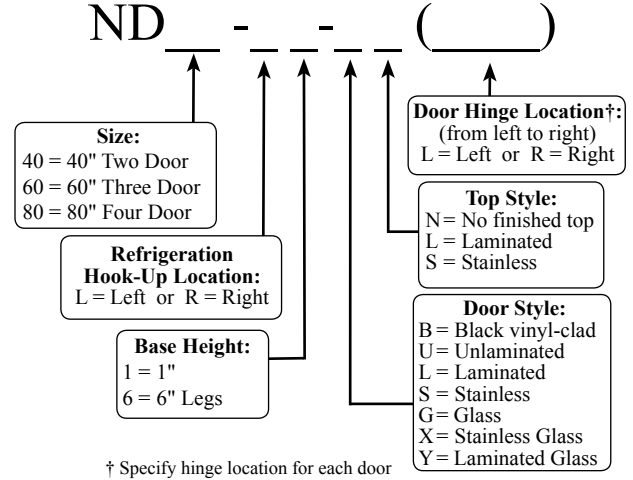

Standard Features

- Remote unit
- All stainless steel interior construction with radius corners for easy cleaning
- Foamed-in-place CFC free insulation
- Galvanized steel sub-top
- Black vinyl-clad steel door and exterior sides
- Stainless steel evaporator housing with separate removable evaporator drain pan
- Stainless steel die cast handle
- Leg sockets recessed into base
- 1/2" thick ABS plastic threshold scuff plate
- 180° swinging doors

Specifications

Electrical

- 120V, 1 phase, 60 Hz
- Dedicated 15 amp circuit is required
- 14 gauge wire connection is made inside the cooler next to evaporator housing - interior access is through one of the 3/4" side knock-out holes (electrician's choice)

Refrigeration

- R134a or R404a expansion valve & temperature control included. Specify type required when ordering.
- Recommended condensing unit:
ND40 - 1/4 HP which has an approximate rating of 2,200 BTU/H at +20°F evaporator temperature
ND60 and ND80 - 1/3 HP which has an approximate rating of 3,064 BTU/H at +20°F evaporator temperature
- All refrigeration hookups are made at the installation site

Plumbing

- A six foot length of 1/2" ID by 5/8" OD plastic tubing is provided to drain condensate. The tubing should exit through one of the 3/4" side knock-out holes (installer's choice). The maximum drainage is one ounce per hour - consult local codes for compliance - a floor drain may be required

Shelving

- Two adjustable coated shelves and one bottom coated rack per door included

Legs

- 1-5/8" diameter
- Stainless steel bullet feet

Materials

- 22 gauge stainless steel parts include: interior floor, walls, ceiling, front of cabinet, and evaporator housing
- 22 gauge black vinyl-clad parts include: sides and standard doors
- 22 gauge galvanized steel parts include: exterior sub-top and back
- 16 gauge stainless steel parts include: legs
- 16 gauge galvanized steel parts include: base
- 16 gauge zinc plated CR steel parts include: leg sockets
- 12 gauge stainless steel parts include: hinges, hinge brackets, and lock brackets

* NOTE: These units are manufactured to order. Consult the factory for pricing information

<p>Glastender, Inc. • 5400 N Michigan Rd • Saginaw, MI • 48604-9780 989.752.4275 • 800.748.0423 • Fax 989.752.4444 www.glastender.com</p>	<p>Approval/Notes:</p>
<p>Specifications subject to change without notice. For current specifications please visit our website.</p>	

Remote Narrow Door Coolers

Dimensional Information

ND40

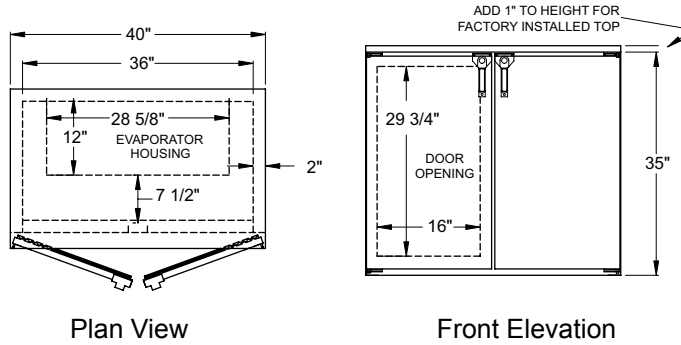

Plan View

Front Elevation

ND60

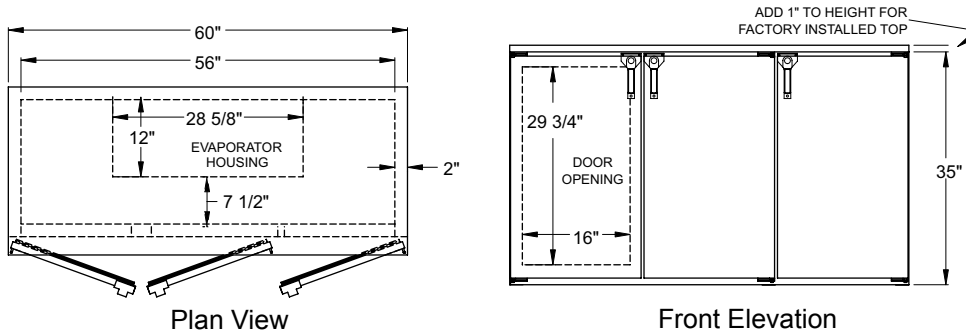

Plan View

Front Elevation

ND80

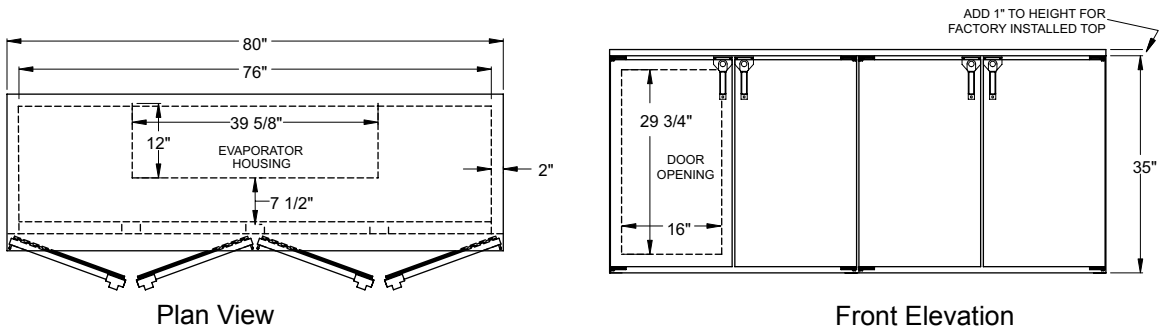

Plan View

Front Elevation

Side View All Models

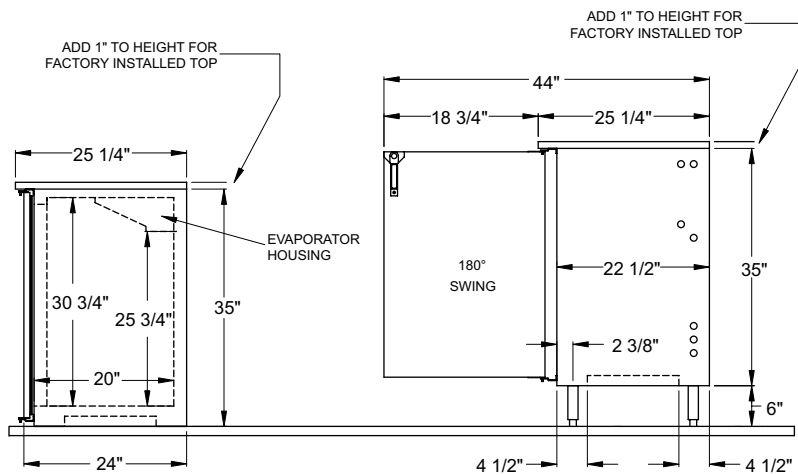

STANDARD CABINET

WITH OPTIONAL 6" LEGS

Model	Capacity: 12 oz. bottle / NOTE: Door width does not allow for keg storage	Refrigeration	Voltage Required
ND40	9.8 cases / No keg storage	1/4 H.P. Recommended	120v / 60 Hz / 1 phase
ND60	14.7 cases / No keg storage	1/3 H.P. Recommended	120v / 60 Hz / 1 phase
ND80	19.6 cases / No keg storage	1/3 H.P. Recommended	120v / 60 Hz / 1 phase



5400 N Michigan Rd • Saginaw, MI • 48604-9780
989.752.4275 • 800.748.0423 • Fax 989.752.4444
www.glastender.com