

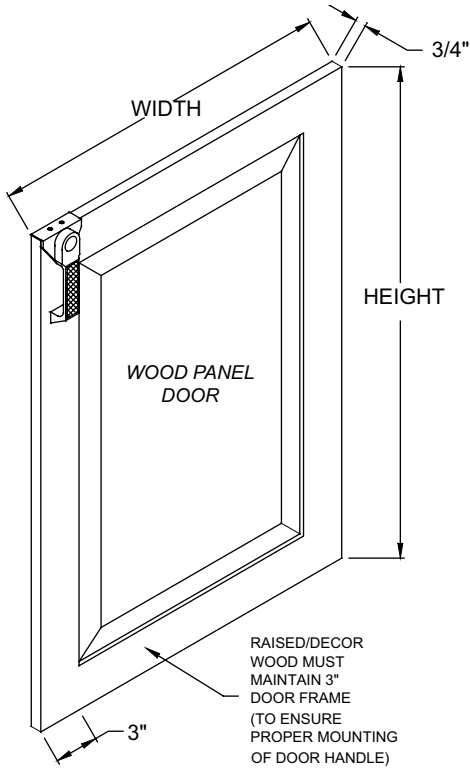

Project: _____	AIA# _____
Item #: _____ Qty: _____	SIS# _____
Model #: _____	

Wood Panel Cooler Door Details



Glastender Back Bar, Narrow Door, Low Profile, Pass Thru, Rear Feed, and Front Venting coolers, Front Venting Mug Chillers, and Dry Storage cabinets can be supplied with hinge hardware to accommodate 3/4" thick wood panel doors attached to the front of the standard black vinyl-clad doors.

The specification when ordering must call out for hinge hardware to accommodate wood panel doors. The cooler top must be at least 26" deep. See also, the wood compressor compartment cover details shown on page 4.31 of this specification guide.

The dimensional details for fabrication of the wood panels doors are illustrated in the detail to the left with the width and height dimensions listed below:

	SERIES	WIDTH	HEIGHT		SERIES	WIDTH	HEIGHT
2" Walls	BB	23-5/8"	33-3/16"	1 1/2" Walls	BB, PT, RF, DS	23-5/8"	33-3/8"
	LP	23-5/8"	27-3/16"		ND	19-5/8"	33-3/8"
	ND	19-5/8"	33-3/16"		LP, FV	23-5/8"	27-1/2"
	NDLP	19-5/8"	27-3/16"		MFV	23-5/8"	24-3/4"

NOTE: Raised panel wood doors do not meet UL flammability test requirements. Coolers manufactured with raised panel wood doors do NOT carry the UL mark. Please verify acceptability with your local electrical inspector prior to ordering.

Wood Panel Door Mounting Instructions

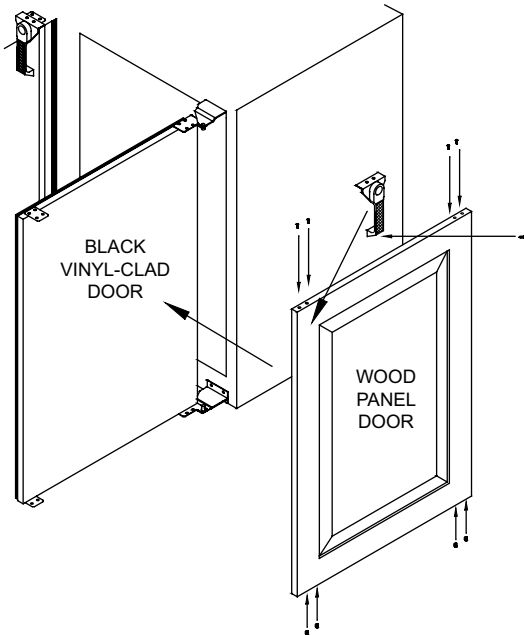

1. Remove the black vinyl-clad door from the cooler by removing the screws from the top hinge. The door can then tilt out from under the hinge and be lifted up off the bottom hinge bracket.
2. Secure the top hinge back in place.
3. Lay the black vinyl-clad door down and position the wood panel on top of it. No sealant or glue is required between the black vinyl-clad door and the wood panel.
4. Align the wood panel accordingly, then pre-drill starter holes in the wood panel through the upper and lower wood panel mounting plates already attached to the black vinyl-clad door. The top and bottom hinge also function as wood panel mounting plates.
5. Mount the wood panel with screws through all of the wood panel mounting plates except the top hinge. The handle must be mounted at this time as well.
6. Remove the top hinge from the black vinyl-clad door and set the bottom hinge pin into the bottom hinge bracket. Be sure to use the plastic spacer washers provided for the upper and lower hinge pins.
7. Place the top hinge on the top hinge bracket pin and then position the door beneath the hinge to align with mounting holes.
8. Fasten the top hinge to the black vinyl-clad door and the wood panel and the installation is complete.

Glastender, Inc. • 5400 North Michigan Road • Saginaw, MI • 48604-9780 989.752.4275 • 800.748.0423 • Fax 989.752.4444 www.glastender.com	Approval/Notes:
Specifications subject to change without notice. For current specifications please visit our website.	